

INSULATED SERVICE DOORS

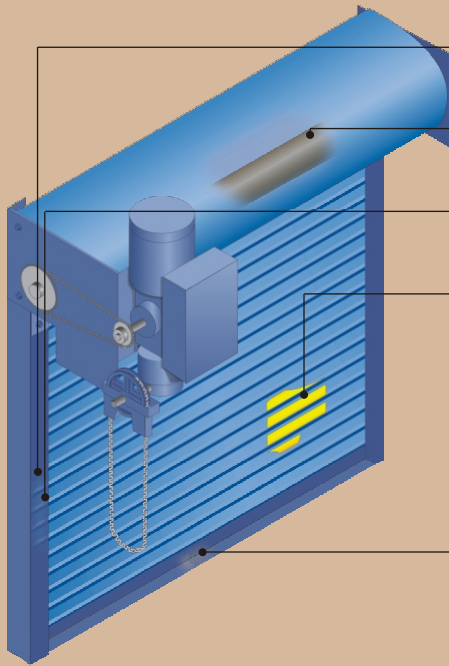

- Heavy duty vinyl extrusions snap into the guides to reduce air and dust infiltration and to weatherstrip the door jambs
- Air seepage around the hood is minimized by a water resistant hood baffle that maintains flexibility in cold temperatures
- Exclusive interlocking slats provide energy efficiency and a finished appearance inside and out
- Solid insulation is inserted between galvanized steel slats to ensure consistent density and complete insulating coverage
- The bottom of the door is sealed by a flexible, solid foam astragal

Choice of Finishes

- FinalCote™ (Standard) (Tan, White, or Gray)
- ColorCote™
- 180 Standard Colors (Optional)
- Unlimited Custom Colors (Optional)
- Stainless Steel #4 Polish
- Aluminum (Mill or Clear Anodized)

INSULATED SERVICE DOOR MODEL NUMBERS

	MOUNTING		OPERATION	
	Face of Wall Between Jamb	Chain	Motor	
FCWI	●		●	
JCWI		●	●	
FMWI	●			●
JMWI		●		●

Unique System for Maximum Insulation

Cookson Insulated Doors boast the same features as service doors plus a unique manufacturing process that keeps thermal losses to a minimum.

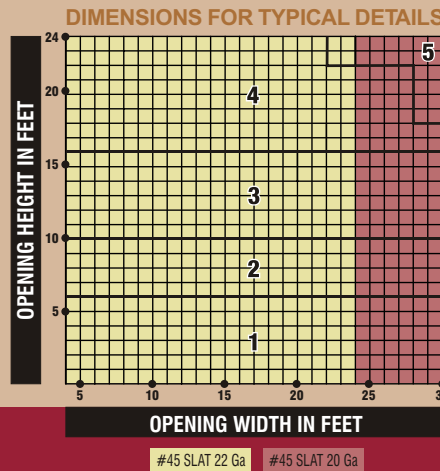

AREA	DIMENSIONS						
	A	B	C	D	W	X	Y
1	18.0"	19.0"	6.5"	9.5"	2.5"	3.0"	3.0"
2	20.0"	21.0"	6.5"	9.5"	2.5"	3.0"	3.5"
3	22.0"	23.0"	6.5"	9.5"	3.0"	3.0"	4.0"
4	24.0"	25.0"	9.5"	9.5"	3.0"	3.0"	5.0"
5	26.0"	27.0"	9.5"	9.5"	3.0"	3.0"	5.0"

E = 3 1/2" with astragal; 5 1/2" with Featheredge

Dimensions are based on #45 Slat 22 ga. front for doors to 24'0" wide, #45 Slat 20 ga. front for doors to 30'0" wide, and #45 Slat 18 ga. front for doors over 30'0" wide. Use of other gauges may increase the dimensions shown.

SLAT & GAUGE SELECTION

#45 Slat	22 Ga. Front / 22 Ga. Back Steel or Stainless Steel	Max. Door Width 24'0"
#45 Slat	20 Ga. Front / 22 Ga. Back Steel or Stainless Steel	Max. Door Width 30'0"
#45 Slat	18 Ga. Front / 22 Ga. Back Steel	Door over 30'0" Width
#45 Slat	.032" Front / .032" Back Aluminum	Max. Door Width 20'0"
#45 Slat	.050" Front / .032" Back Aluminum	Max. Door Width 30'0"

TYPICAL DETAILS

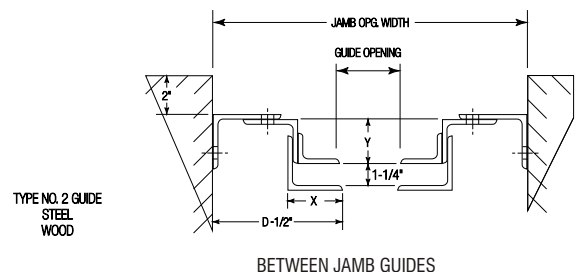
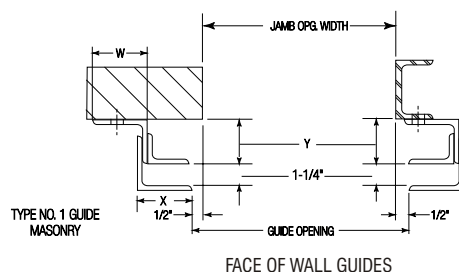
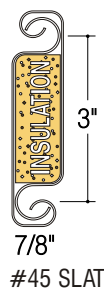
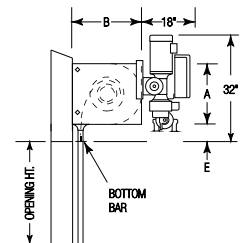
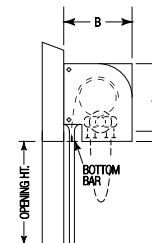
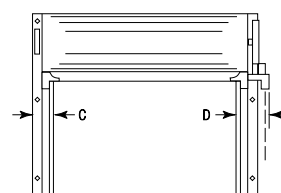

ASHRAE calculations for the U-Factor.

U Factor 0.159

R Value 6.29

Tested or actual Values may vary from calculated values.