



COOKSON OWNER'S MANUAL



VERSION 6.1

WIRELESS SELF MONITORING SENSING EDGE SYSTEM

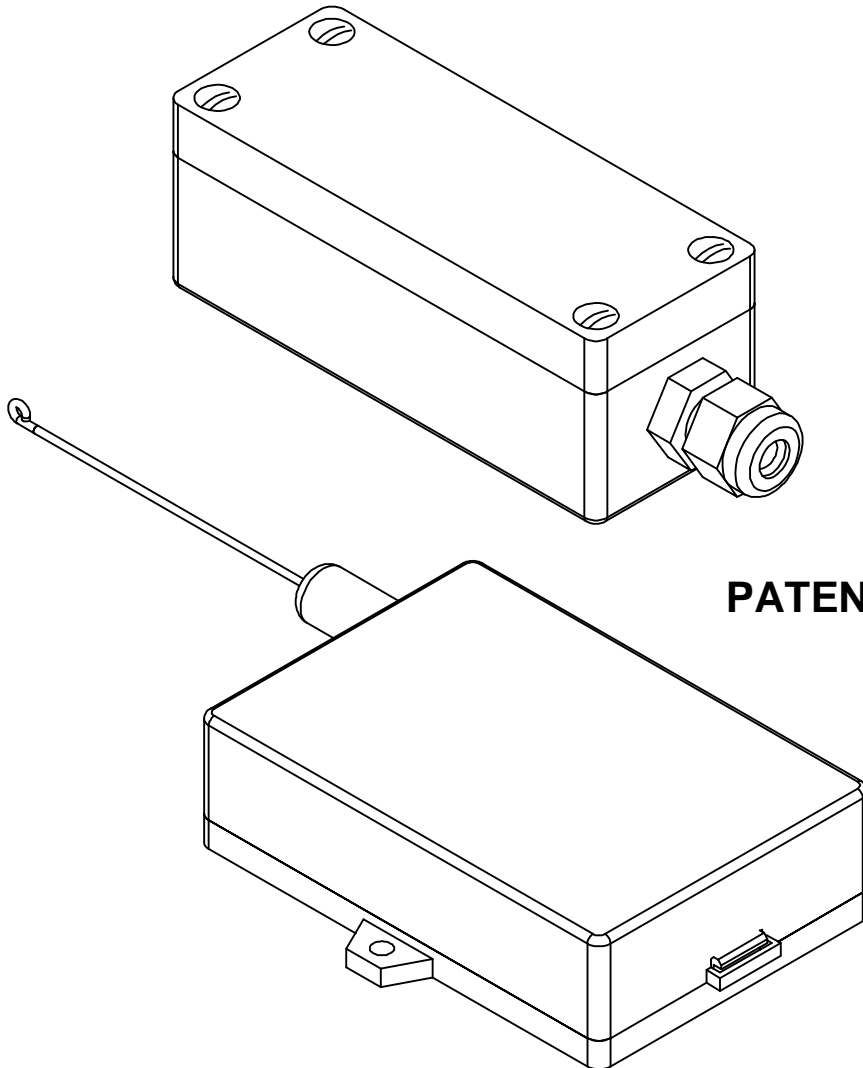

PATENT NO. 6,225,768

SPECIFICATIONS

COMPATIBLE WITH THE FOLLOWING 2010 UL325 COMPLIANT OPERATORS WHEN USED IN CONJUNCTION WITH APPROVED PRIMARY ENTRAPMENT PHOTO EYES PRESCRIBED BY OPERATOR MANUFACTURER: LIFTMASTER - LOGIC 4.0, MICANAN LOGIC 10 & MECHANICAL OPERATORS USING INTERFACE MODULE, FDO-AU & FDO-BU, FDO-A10, COOKSON MG SERIES & SGH OPERATORS. NOT COMPATIBLE WITH OTHER (RF) RADIO FREQUENCY DEVICES.

TRANSMITTER

ENCLOSURE MATL:.....POLYCARBONATE
 ENCLOSURE COLOR:.....BLACK
 ENCLOSURE RATING:.....NEMA 4
 OPERATING TEMP:.....-25° F TO 120° F
 OPERATING FREQUENCY:..315 Mhz
 MAX OPER DISTANCE:.....50 FT
 POWER:.....9 VOLT LITHIUM BATTERY
 EXPECTED BATTERY LIFE:..12 MOS-NORMAL USAGE
 ANTENNA TYPE:.....PCB LOOP
 SPECIAL FEATURES:
 - PROGRAMMABLE TRANSMITTER CODES
 - DETECTS LOW BATTERY VOLTAGE
 - LED INDICATOR

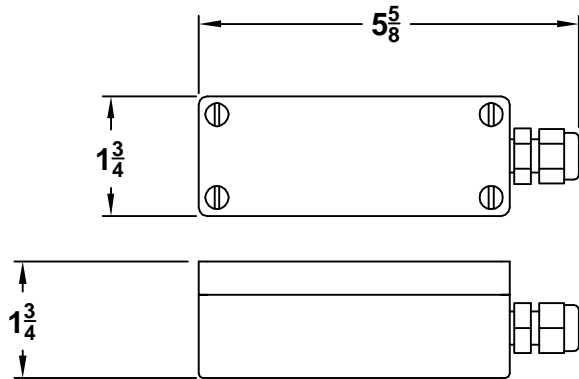

RECEIVER

ENCLOSURE MATL:.....ABS
 ENCLOSURE COLOR:.....BLACK
 OPERATING TEMP:.....-25° F TO 120° F
 MAX OPER DISTANCE:.....50 FT
 POWER:.....24 VOLT AC OR DC
 ELECTRICAL CONFIG:.....OPTIONAL N.O. OR N.C.
 ANTENNA TYPE:.....COAX RIGID WIRE
 SPECIAL FEATURES:
 - PROGRAMMABLE RECEIVER CODES
 - LED INDICATORS

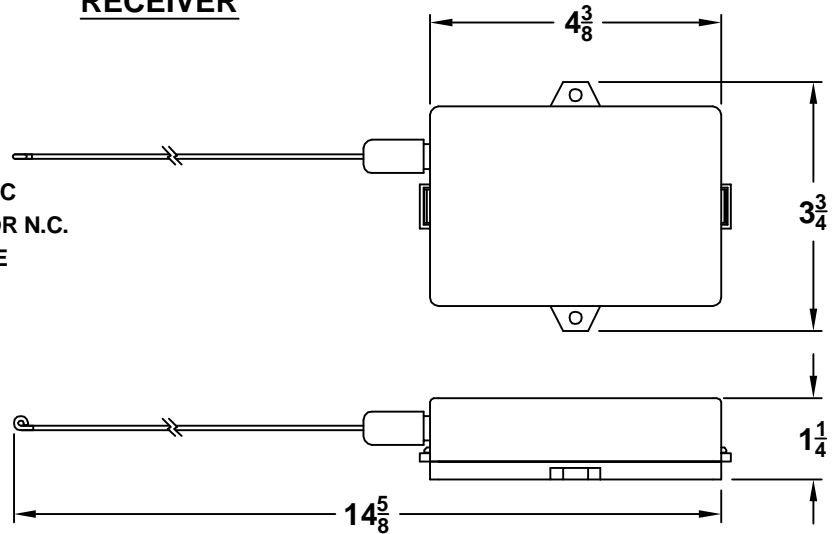

PACKAGE CONTENTS:

<u>DESCRIPTION</u>	<u>QTY</u>
RECEIVER W/WIRING HARNESS	1
TRANSMITTER W/ADHESIVE TAPE	1
BATTERY-9 VOLT LITHIUM	1
ANTENNA	1
#6 RHMS SCREWS	2
WIRE NUT	1
OWNERS MANUAL	1

THEORY OF OPERATION

GENERAL DESCRIPTION:

The Phantom Edge is a self monitoring wireless (RF) sensing edge system. A special communication protocol between the transmitter and receiver allow for additional signals (other than edge activation) to be sent, such as battery condition and periodic communication checks. If the unit detects a fault it will convert the operator to supervised mode (i.e. constant pressure contact on operator close control) indicating that maintenance is required.

OPERATION:

When the Bottom Bar encounters an obstruction, the Transmitter sends reversing signal to the Receiver, reversing the door. The unit has self check features, which ensure that the device is functioning properly.

- The unit periodically tests communication by sending a signal at regular intervals.
- Low Battery Voltage condition

If any of the above occur (not occur) the unit will enter into Supervised Mode: Constant pressure will be required on close door operation until fault is corrected.

INSTALLATION INSTRUCTIONS



TO PREVENT ELECTROCUTION DISCONNECT POWER AT FUSE BOX OR CIRCUIT BREAKER AND OPERATOR BEFORE WIRING



FOLLOW ALL LOCAL BUILDING CODES AND NATIONAL ELECTRICAL CODES. IMPROPER WIRING COULD CAUSE ELECTROCUTION OR DAMAGE TO CIRCUITRY

NOTES:

- BEFORE INSTALLING, VERIFY THAT YOU HAVE A COMPATIBLE OPERATOR .
- OPERATOR SHOULD BE COMPLETELY WIRED AND FUNCTIONAL PRIOR TO INSTALLING PHANTOM EDGE SYSTEM.

TRANSMITTER INSTALLATION:

- 1) Locate position on Bottom Bar near Sensing Edge pigtail. (Approx. 18" from end of Bottom Bar)
- 2) Clean the vertical surface where the Transmitter is to be mounted on the Bottom Bar.
- 3) Remove the protective film from the adhesive backed foam tape and attach it to the back of the Transmitter box. Attach the Transmitter box to Bottom Bar vertical surface with the label facing outward, not up.

NOTE: If your installation requires the use of mounting screws, remove the cover from transmitter, the mounting holes are at the corners (at cover screw locations). DO NOT drill any holes in the Transmitter box.

- 4) Connect the sensing edge pigtail to the transmitter per the detail shown on the next page.

- 5) Be sure that the battery strap is connected and insert the lithium ion 9 Volt battery into the cover of the unit, and replace the cover. The green LED light should light indicating that the unit is functioning properly.

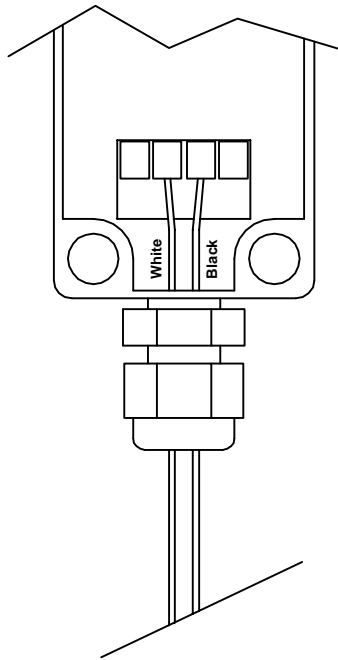

**2 - Wire
Connections
Dip Switch #5 "ON"**

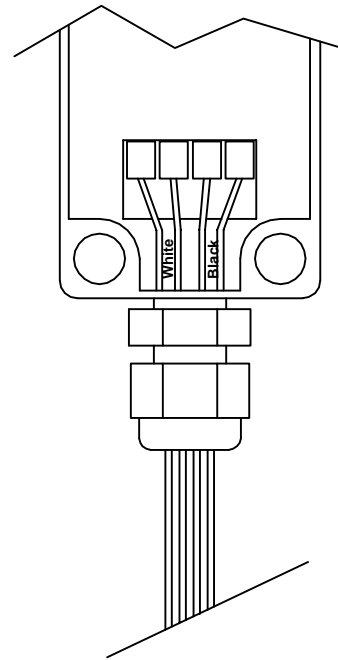

**4 - Wire
Connections
Dip Switch #5 "OFF"**

RECEIVER INSTALLATION:



CAUTION: DISCONNECT POWER TO OPERATOR

- 1) Locate the Receiver on the Operator Control Enclosure, with Antenna horizontal and free of obstructions. Make sure a knock out is accessible, and that mounting screws will clear internal components of the door operator.
- 2) Wire to Operator per operator specific wiring diagram. (See Appendix for Wiring Diagrams)
- 3) Attach Coax Rigid Wire antenna. (The unit will not work unless the rigid antenna is properly attached) (Units with Motor Covers will require a remote antenna kit to mount the antenna outside the motor cover)
- 4) Verify that the dip switches in the Receiver and Transmitter are set properly.
- 5) Verify correct wiring. Restore power to Operator.



CAUTION
BE SURE THAT ALL COAX FITTINGS AND COAX WIRES DO NOT COME IN CONTACT WITH ANY PART OF THE METAL CONTROL BOX. THIS WILL RESULT IN A SHORT, AND WILL DAMAGE THE RECEIVER.

START UP / TESTING PROCEDURES

INITIAL POWER UP:

- 1) The unit will be in "Supervised Mode":
Constant pressure required on door CLOSE control
- 2 LED's under the label will be lit.
- 2) Hold closed door control:
- (D3) "Transmitter Awake" (GREEN) LED will lite when door is in motion.
- (D8) "Signal Acquired" (GREEN) LED will lite when edge is pressed.
- 3) When door closes completely:
- (D5) "Edge Activation" (AMBER) LED will light for several seconds.
- 4) Receiver will switch to "Normal Mode":
- (D6) "Normal Mode" (GREEN) LED will light.
Door now requires momentary contact for CLOSE control.

RECEIVER (ON OPERATOR)

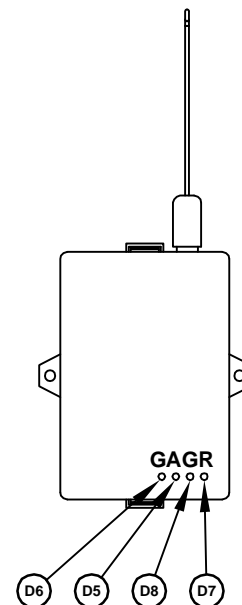

LED LEGEND-RECEIVER

D6	GREEN	NORMAL MODE
D5	AMBER	EDGE ACTIVATION
D8	GREEN	SIGNAL ACQUIRED
D7	RED	CHECK BATTERY

TEST CLOSED DOOR CHECK:

- 1) With door several feet from closed position, disable sensing edge connection to the Transmitter.

Electrical Edge:

- Unplug quick disconnect plug connecting Transmitter to Sensing Edge.
- (D7) "Check Battery" (RED) LED should not be lit.

Unit should switch to "Supervised Mode":
Constant pressure required on door CLOSE control.
- (D6) "Normal Mode" (GREEN) LED will turn off.

TRANSMITTER (ON BOTTOM BAR)

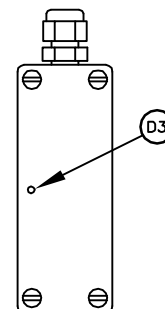

LED LEGEND-TRANSMITTER

D3	GREEN	TRANSMITTER SENDING
----	-------	---------------------

- 3) Open door several feet - Verify that unit is still in "Supervised Mode". Constant pressure required on door CLOSE control.
- 4) Reconnect sensing edge to Transmitter.

Unit will switch to "Normal Mode".

- (D6) "Normal Mode" (GRN) LED will light. Door now requires momentary contact for CLOSE control.

TROUBLESHOOTING

- 1) Verify address selection dip switches (1 thru 4) are set the same on the Transmitter and Receiver.
- 2) Check the Battery voltage first. Minimum 7 Volts. Replace battery if voltage is at or below minimum.

DIP SWITCH CONFIGURATIONS

RECEIVER SWITCH SETTINGS

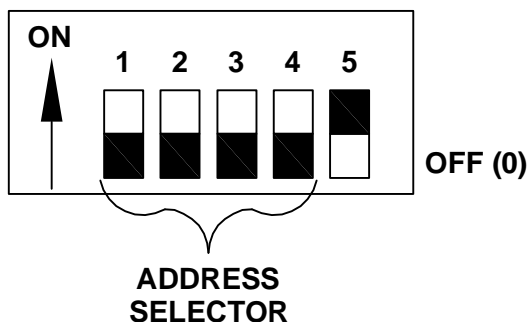

TRANSMITTER SWITCH SETTINGS

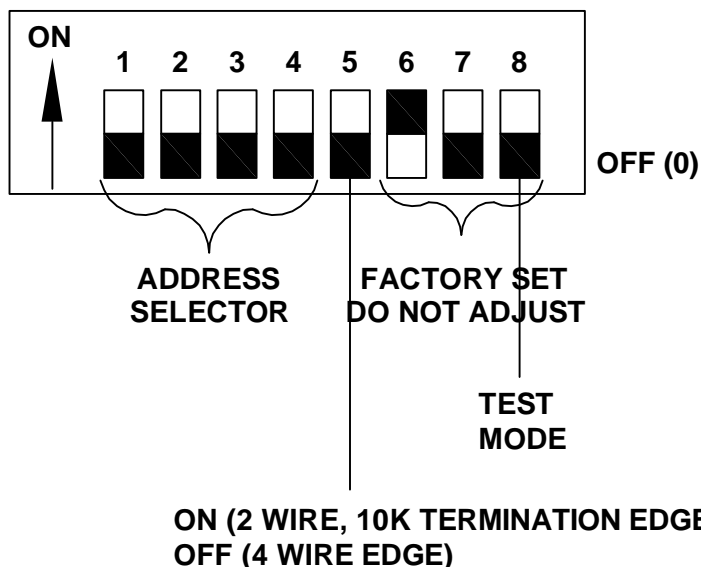

- 3) Make sure the antenna is attached to the receiver, and that the "tip" of the antenna is NOT aimed at the transmitter (the side of the whip antenna is what picks up the signals, not the tip).
- 4) Do NOT mount the antenna inside a closed metal box; the box will shield the antenna from all signals, and the receiver will not work as a result. If the receiver must be mounted inside a metal box, use an antenna extension kit to mount the antenna on the outside of the metal box.
- 5) Make sure the transmitter is mounted so that when the door is partly open, you are looking directly at the label on the lid and not looking at the side of the case.

DOOR WON'T CLOSE OR REVERSES TO FULL OPEN WHEN IT ATTEMPTS TO CLOSE:

- 1) Receiver has no power and the Safety Edge relay output is "closed" as a result.
 - Ensure that a STEADY 24 Volts are present; If DC is used, the red lead must be "positive" polarity.
- 2) Make sure that the receiver switch #5 is "ON" for 2-wire w/termination; "OFF" for 4-wire Phantom Edge.

DOOR STAYS IN CONSTANT PRESSURE MODE:

- 1) Receiver has had a Power-On-Reset and has not heard from the sensing edge transmitter since the power-on, causing a Communication Time-Out Fault (the red LED on the receiver will be "ON" solid).
 - * Check that the power to the receiver STAYS on when the limit switches are reached, and when any of the Operator push buttons are pressed.
- 2) Receiver has a slowly blinking red LED; this means that the transmitter has a low battery.
 - * Use a lithium 9-volt battery for cold weather operation; an alkaline battery will work in mild weather; but has about half the capacity of the lithium types.
- 3) Receiver has a fast blinking red LED; this means that the transmitter sees a sensing edge termination fault. If the edge is a 4-wire type, one of the safety edge wires may not be making contact in the connector in the transmitter; or the sensing edge is faulty. If the edge is of the terminated 2-wire type, the transmitter is not seeing the terminator resistor.
 - * Make sure that switch #5 on the transmitter is OFF for 4-wire, and ON for terminated 2-wire. This unit will not function correctly with a non-terminated 2-wire edge. The terminated edges can be identified two ways; 1) There will be a blue band around the pigtail as it exits the edge; 2) The edge will measure 10K ohms between the two leads if checked with a multimeter.

DOOR FAILS TO REVERSE WHEN IT CONTACTS AN OBSTACLE:

- 1) Check that the Door Operator "sensing edge cut out" switch is correctly adjusted to within 6" of the floor.
- 2) Check that the receiver's sensing edge relay output wires are intact and still connected to the Door Operator's sensing edge input terminals.
- 3) Check the receiver sensing edge relay output jumper; the jumper should be placed on the N/O pins for the channel (green and orange wires) normally-open relay contacts.

TO TEST FOR A RF SHORT-RANGE PROBLEM BETWEEN THE TRANSMITTER AND RECEIVER

For a BRIEF TEST, turn on the transmitter's test mode switch, #8, and activate the safety edge to initiate a transmission. The transmitter will come on and stay on until the switch #8 is turned back off for normal operation. The receiver Signal Acquired green LED (next to the red Maintenance Required LED) should come on and stay on while the door is run through its' range of motion. The safety edge should work as usual while in test mode. **TURN OFF "TEST MODE" AS SOON AS POSSIBLE**, to avoid undue RF interference and also quickly exhausting the transmitter battery.

REMEMBER:

An ACTIVE SENSING EDGE to the transmitter will cause the receiver sensing edge output relay to stay ACTIVE.

ALL FAULT CONDITIONS (low battery, edge termination not sensed, communications time out) cause the receiver to put the door operator into Constant Pressure mode.

Check the condition of the receiver's indicator lights at the time of the problem, to quickly find the cause.

Some locations are much more electrically noisy than others. If the receiver shows signs of performing a "power-on" light test when the operator's motor starts or stops, or other heavy equipment in the vicinity seems to be affecting the wireless link, please contact Miller Edge with the necessary information (mounting location, plus the make and model of the door operator or other related equipment) to resolve the problem.

LABEL AND MANUAL INFORMATION

1) Labeling Requirement

In accordance with the Section 15.19 of FCC Rules, a permanently attached label shall be affixed to every product in a conspicuous location with the following statement:

"This device complies with part 15 of the FCC Rules. Operation is subject to the following two conditions: 1) This device may not cause harmful interference, and 2) this device must accept any interference received, including interference that may cause undesired operation."

(a) For a class A digital device or peripheral, the instructions furnished the user shall include the following or similar statement, placed in a prominent location in the text of the manual:

"Note: This equipment has been tested and found to comply with the limits for a Class A digital device, pursuant to Part 15 of the FCC Rules. These limits are designed to provide reasonable protection against harmful interference when the equipment is operated in a commercial environment. This equipment generates, uses, and can radiate radio frequency energy and, if not installed and used in accordance with the instruction manual, may cause harmful interference to radio communications. Operation of this equipment in a residential area is likely to cause harmful interference in which case the user will be required to correct the interference at his own expense."

(b) For a class B digital device or peripheral, the instructions furnished the user shall include the following or similar statement, placed in a prominent location in the text of the manual:

"Note: This equipment has been tested and found to comply with the limits for a Class B digital device, pursuant to Part 15 of the FCC Rules. These limits are designed to provide reasonable protection against harmful interference when the equipment is operated in a commercial environment. This equipment generates, uses, and can radiate radio frequency energy and, if not installed and used in accordance with the instruction manual, may cause harmful interference to radio communications. However, there is no guarantee that interference will not occur in a particular installation. If this equipment does cause harmful interference to radio or television reception, which can be determined by turning the equipment off and on, the user is encouraged to try to correct the interference by one or more of the following measures:

- Reorient or relocate the receiving antenna.
- Increase the separation between the antenna and receiver.
- Connect the equipment into an outlet on a circuit different from that to which the receiver is connected.
- Consult the dealer or an experienced radio/TV technician for help."

2) Information to User

The user's manual or instruction manual for an intentional or unintentional radiator shall caution the user that changes or modifications not expressly approved by the party responsible for compliance could void the user's authority to operate the equipment.

APPENDIX INDEX

<u>DESCRIPTION</u>	<u>PAGE</u>
<u>LIFTMASTER</u>	
WIRING DIAGRAM - LIFTMASTER LOGIC 4.0	A-1
WIRING DIAGRAM - FDO-AU / FDO-BU	A-2
<u>MICANAN</u>	
WIRING DIAGRAM - LOGIC 10	A-3
WIRING DIAGRAM - MECHANICAL	A-4
<u>COOKSON</u>	
WIRING DIAGRAM - FDO-A10 E/EP	A-5
WIRING DIAGRAM - MG	A-6
WIRING DIAGRAM - SGH	A-7
GENERAL WIRING INFO	A-8

LIFTMASTER LOGIC 4.0

WIRING DIAGRAM

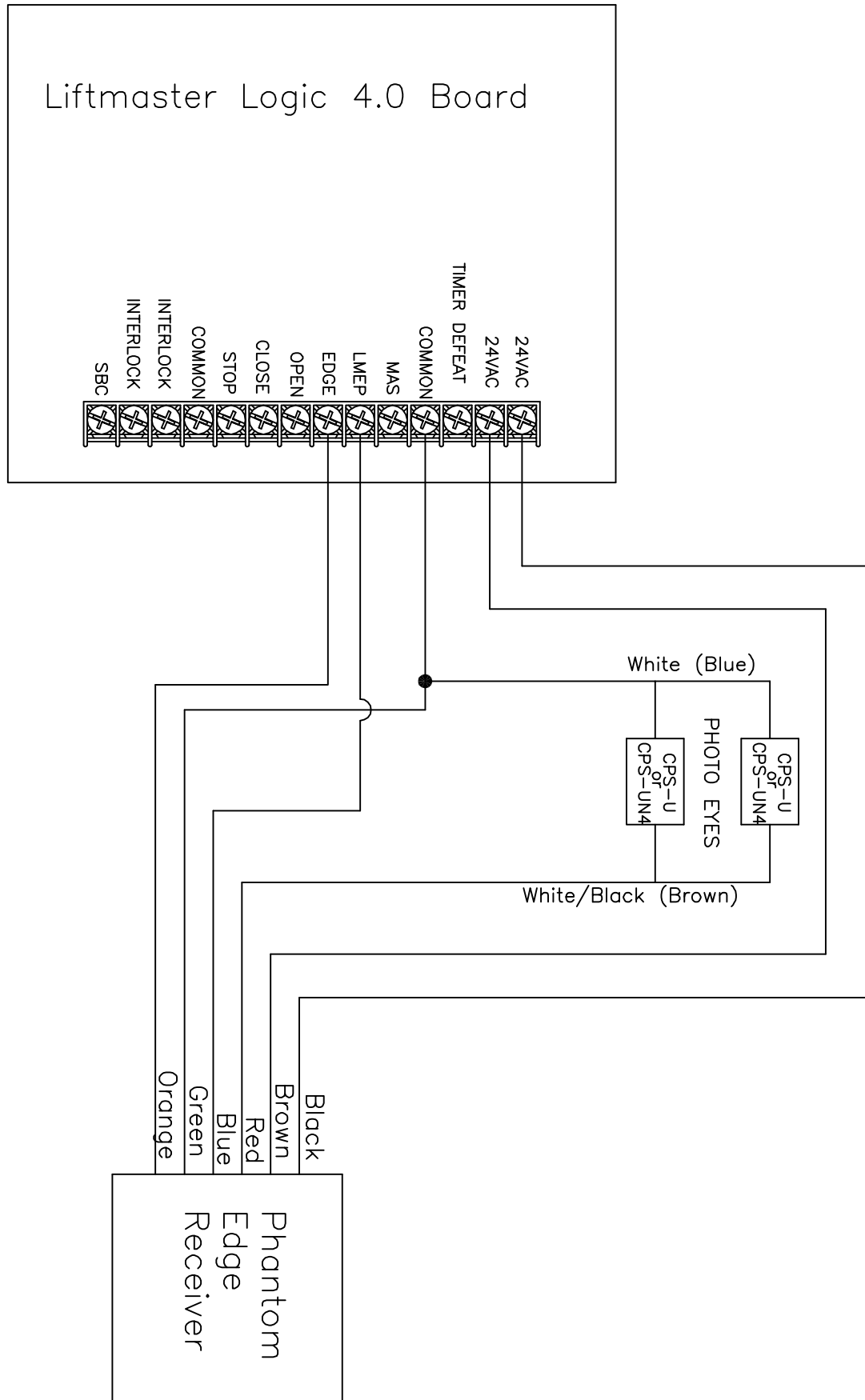

LIFTMASTER FDO-AU / FDO-BU

WIRING DIAGRAM

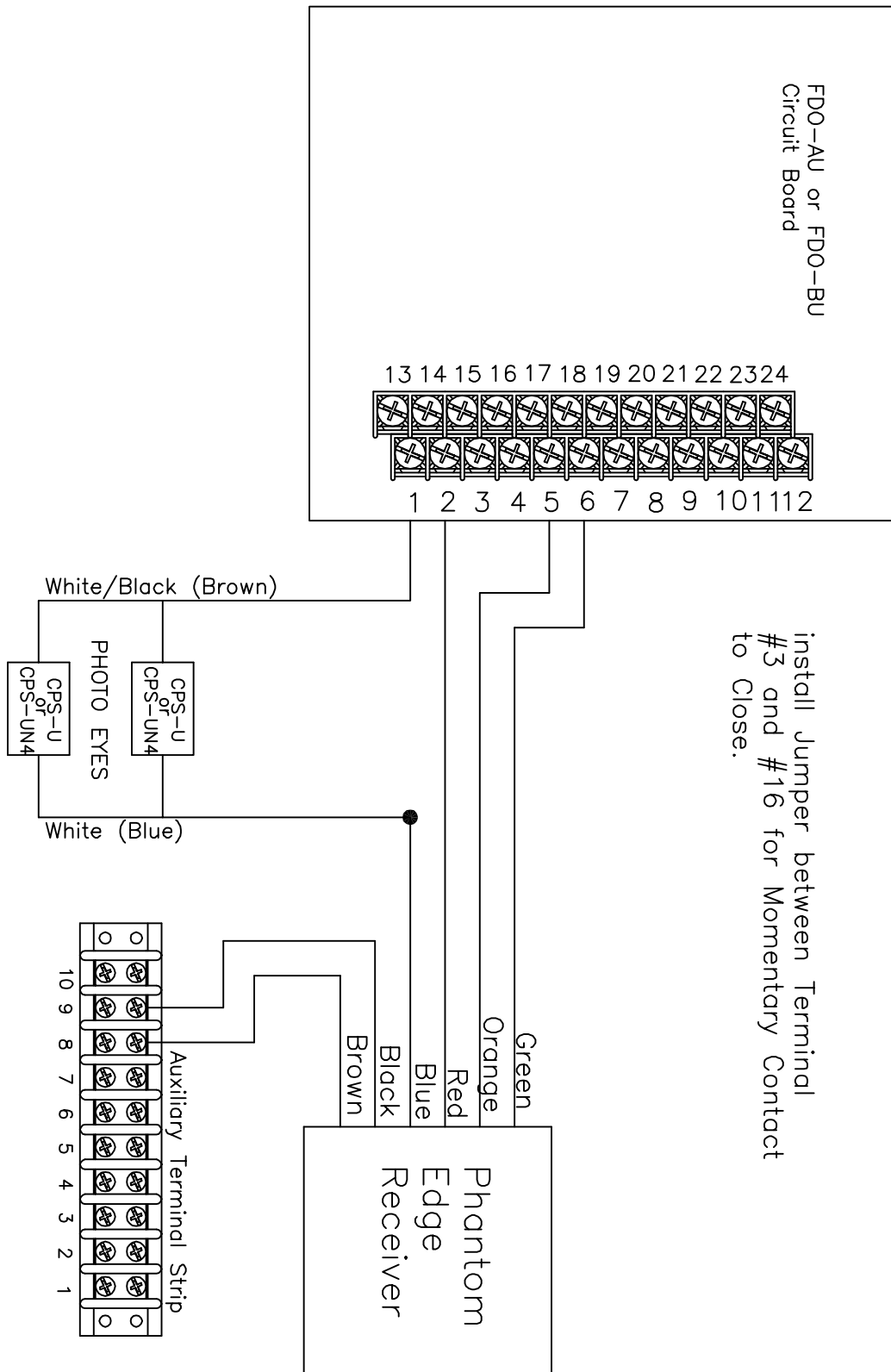

MICANAN LOGIC 10

WIRING DIAGRAM

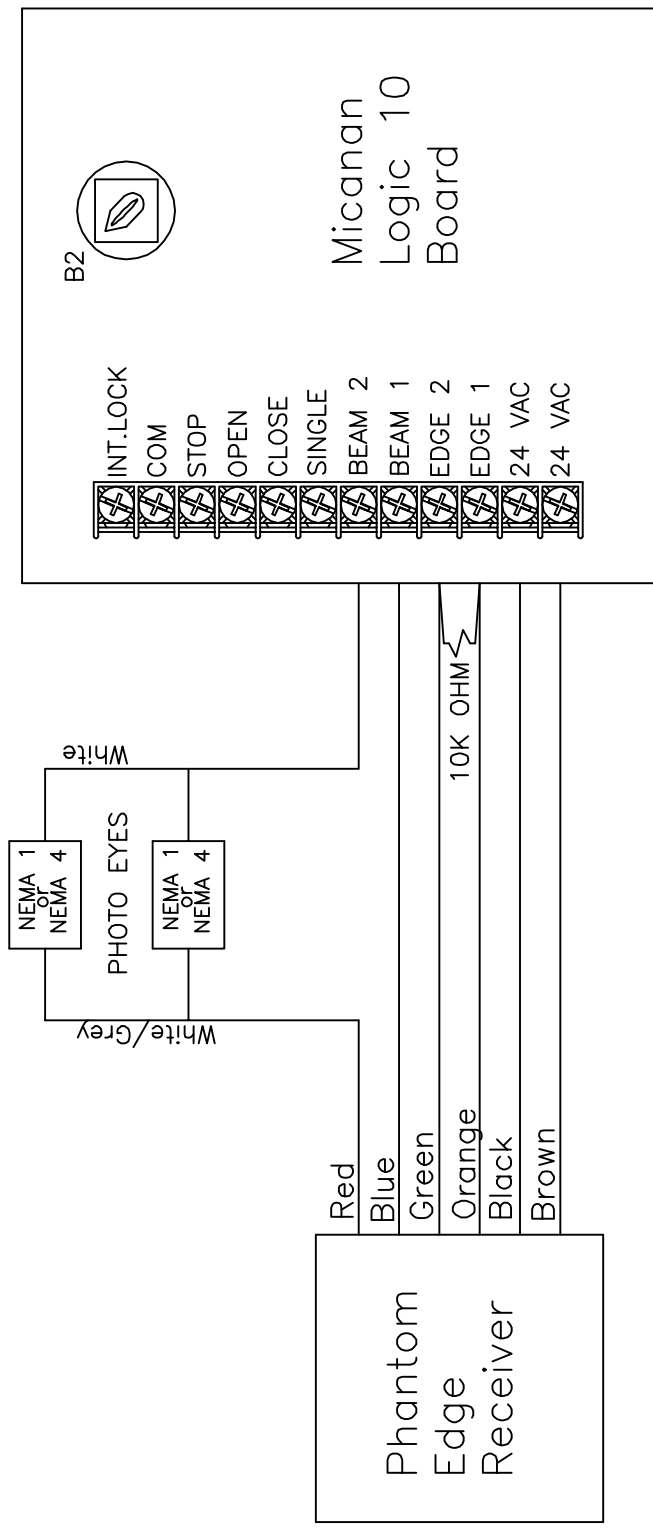

MICANAN MECHANICAL

WIRING DIAGRAM

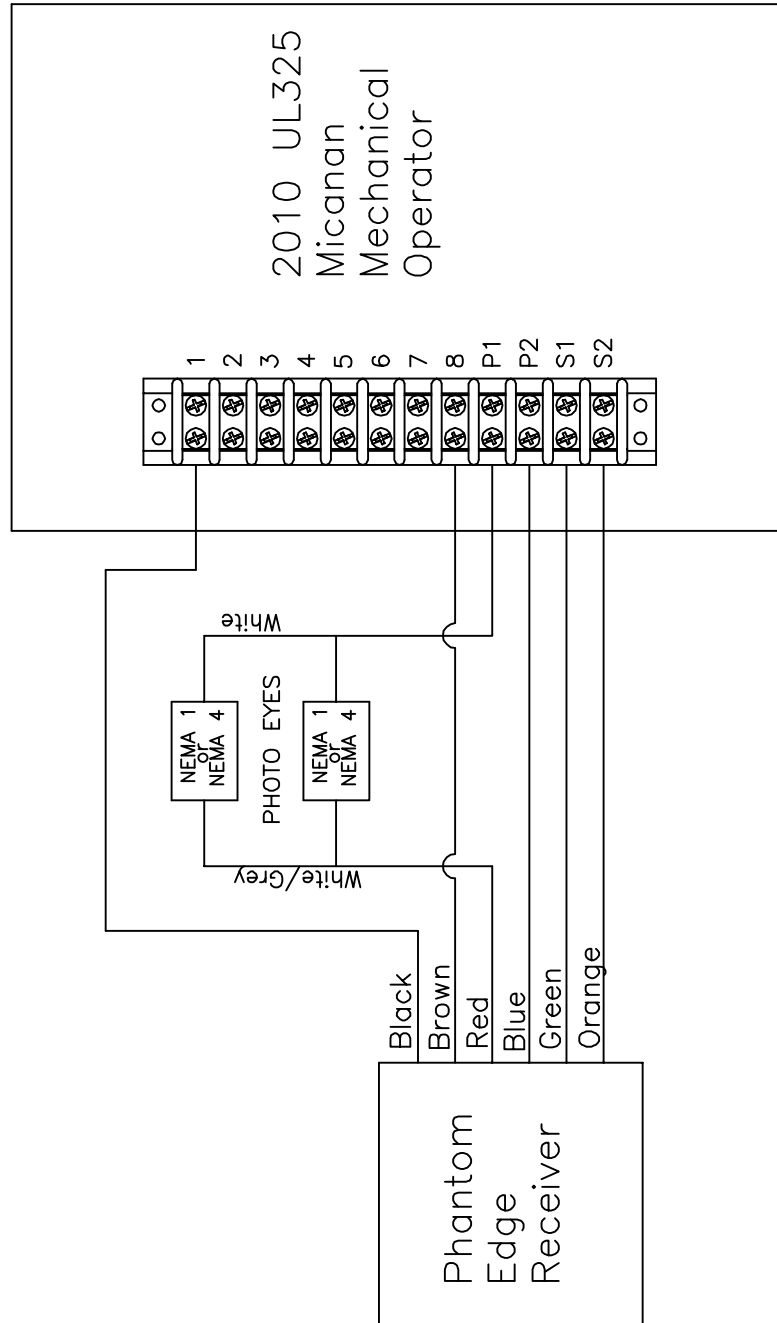

COOKSON FDO-A10 E/EP WIRING DIAGRAM

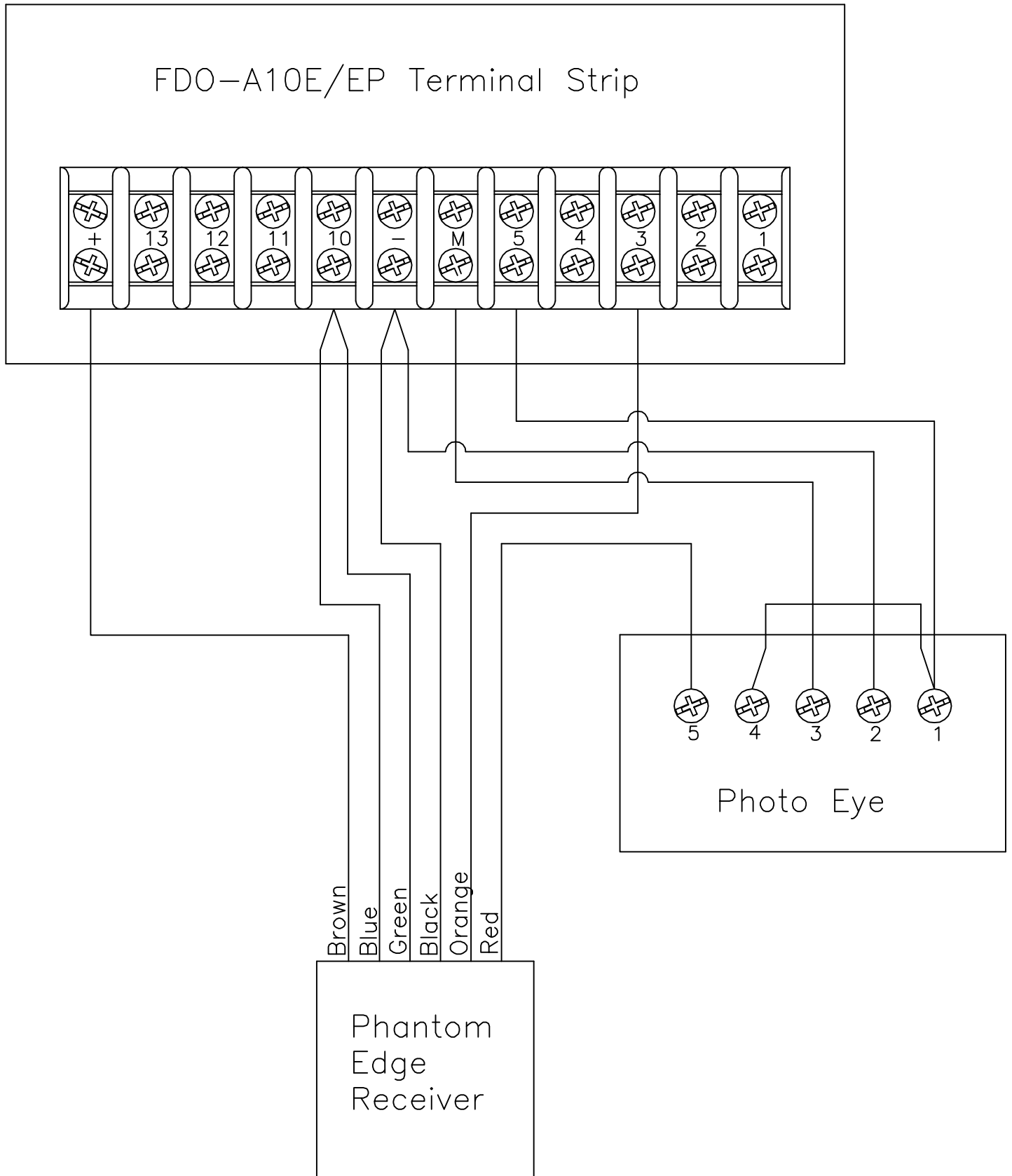

COOKSON MG WIRING DIAGRAM

Hybrid Connections (Cookson MG Series Operators)

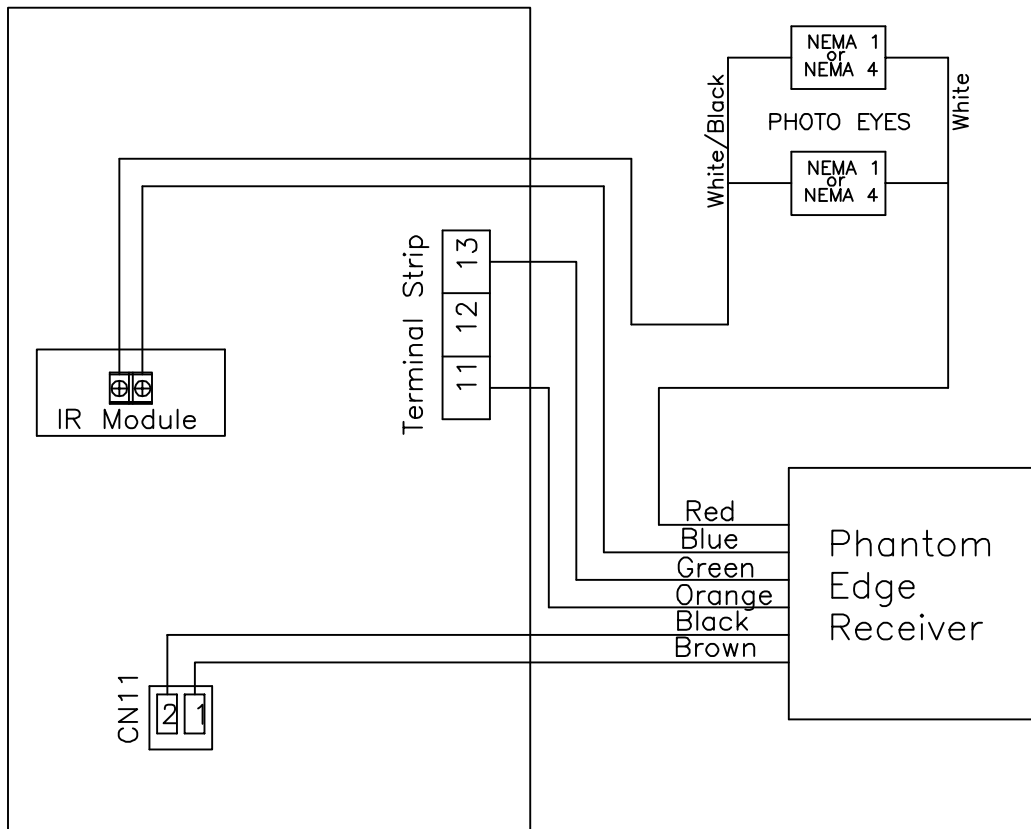

COOKSON SGH WIRING DIAGRAM

SMART BOARD (Cookson SGH Operators)

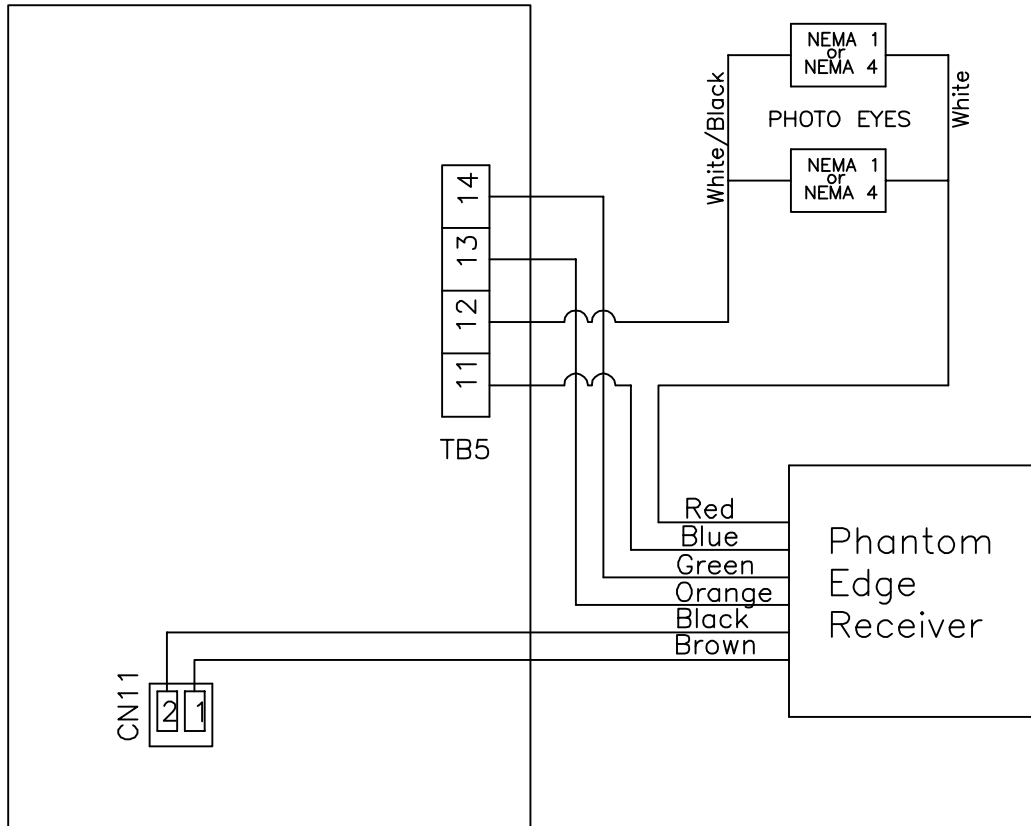

GENERAL WIRING INFO

Phantom Edge – General Connection Wiring Information

